

(SEE DETAIL: SHEET 2 OF 3)

MAJOR PARTITION PLAT No. P2010-009
A Portion of The West 1/2, NW 1/4 of Section 11, & The East 1/2, NE 1/4 of Section 10, Township 9 South, Range 39 East of the Willamette Meridian, Baker County, Oregon
 Survey Completed June 21, 2010

"PARCEL 1"
 E1/2 NE1/4

"PARCEL 1"
 AREA:
 149.94 ACRES

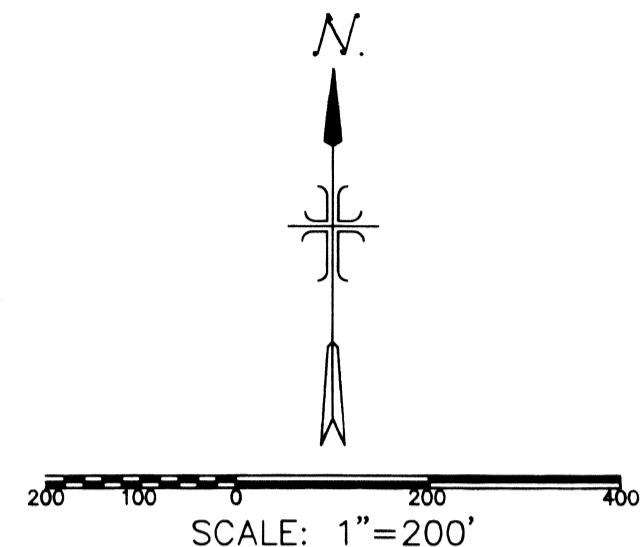

SEE SHEET 2 OF 3 FOR ADDITIONAL SECTIONAL BREAKDOWN INFORMATION
 N00°42'18"E 2643.21'

NOTES:

- 1) ELECTRICAL POWER IS CURRENTLY AVAILABLE TO THE PARCELS WITHIN THIS PARCEL.
- 2) SEWAGE DISPOSAL SHALL BE PROVIDED BY A DEQ APPROVED SANITARY SEWAGE DISPOSAL FACILITY.

REFERENCES

- (1) RECORD OF SURVEY No. 9-39-29
- (2) STATUTORY BARGAIN & SALE DEED B05 26 0371, B05 26 0372 & B05 26 0373
- (3) PARTITION PLAT No. 9-39-256MP
- (4) RECORD OF SURVEY No. 9-39-18
- (5) QUIT CLAIM DEED B10 20 0085 THRU 0087

SURVEY FOR

BETTY GREEN
 42278 WASHINGTON GULCH ROAD
 BAKER CITY, OREGON 97814

REGISTERED PROFESSIONAL LAND SURVEYOR
Lawrence H. Koerner

OREGON
 JAN. 23, 2001
LAWRENCE H. KOERNER
 E-2 42
 7/20/10
 EXPIRATION DATE: 7/31/10

BASIS OF BEARING (1)
 N00°37'10"E 2638.70' (1)

"PARCEL 2"
 AREA:
 5.00 ACRES

"PARCEL 3"
 AREA:
 4.97 ACRES

CIL POCAHONTAS ROAD

WASHINGTON GULCH ROAD

LEGEND

	Boundary Line
	Section Line
	Parcel Line
	Easement Line
	Existing Fence
	Right-of-Way
	Centerline
	Top of Bank
	Found Brass Cap
	Found 5/8" Iron Pin
	Found Railroad Spike
	Found PK Nail
	Set 5/8" Iron Pin W/Plastic Cap "Koerner LS 64242"
	Calculated Point
	Data of Record

SW CORNER
 E1/2 NE 1/4 SECTION 10
 (SEE DETAIL SHEET 2 OF 3)

C 1/4 CORNER(1)

STATEMENT OF WATER RIGHTS

THERE ARE WATER RIGHTS APPURTENANT TO THIS PARTITION AS LISTED UNDER CERTIFICATE NO'S 4446, 83236, 66278, 66277 & 550217. FIVE ACRES FOR PARCEL 3 & THREE ACRES FOR PARCEL 2 ACCORDING TO THE WATER MASTERS APPROVAL FORM DATED 6/29/10.

Koerner Land Surveying & Planning
 2963 W. Fieldstream Dr.
 Meridian, Idaho
 208-830-4168

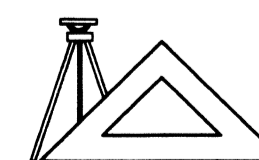

PREPARATION DATE: 7/20/2010 9:08:46 AM