

HANLEY ENGINEERING, INC.
P.O. BOX 701, 2043 MAIN STREET, BAKER CITY, OREGON 97814 (541) 523-3803

PARTITION PLAT NO. P2010-008

A REPLAT OF PARCEL 2, MINOR PARTITION PLAT P1994-012
LOCATED IN THE SOUTHEAST 1/4 OF THE NORTHWEST 1/4 OF SECTION 22,
TOWNSHIP 9 SOUTH, RANGE 45 EAST, WILLAMETTE MERIDIAN,
BAKER COUNTY, OREGON.

JULY 4, 2010

SURVEYOR'S CERTIFICATE

I, THOMAS J. HANLEY, A REGISTERED PROFESSIONAL LAND SURVEYOR IN THE STATE OF OREGON, DO HEREBY CERTIFY THAT I HAVE CORRECTLY SURVEYED AND MARKED ON THE GROUND WITH PROPER MONUMENTATION IN ACCORDANCE WITH O.R.S. CHAPTER 92, A PARCEL OF LAND LOCATED IN THE SOUTHEAST 1/4 OF THE NORTHWEST 1/4 OF SECTION 22, TOWNSHIP 9 SOUTH, RANGE 45 EAST, WILLAMETTE MERIDIAN, BAKER COUNTY, OREGON, BEING MORE PARTICULARLY DESCRIBED AS FOLLOWS:

PARCEL 2, PARTITION PLAT P1994-012, BAKER COUNTY PLAT RECORDS CONTAINING 10.13 ACRES.

DITCH EASEMENT

EASEMENT IS CONVEYED TO THOSE WITH A LEGAL WATER RIGHT FOR IRRIGATION BEYOND THE BOUNDARY OF SAID PARCEL FED BY ANY EXISTING IMPROVED DITCH. TO THOSE PERSONS, IS GRANTED A PERPETUAL, NON-EXCLUSIVE EASEMENT FOR IT AND IT'S LATERALS, FEEDERS AND SUB-DITCHES, HEADGATES AND OTHER APPURTENANCES TO OPERATE, USE MAINTAIN, ETC., RESTORE AND REPAIR, WITH HEAVY EQUIPMENT WHEN NEEDED. THE TOTAL WIDTH SHALL EQUAL THE BANK TO BANK DITCH WIDTH, PLUS 15 FEET BEYOND THE BANK ON EACH SIDE OF THE DITCH. REASONABLE ACCESS TO THE EASEMENT WILL BE GRANTED AT LOCATION DESIGNATED BY THE PROPERTY OWNER, UNLESS OTHER REASONABLE ACCESS IS AVAILABLE.

NOTES

- THIS PROPERTY CONTAINS 9.6 ACRES OF WATER RIGHTS PER WATER RIGHT CERTIFICATE NUMBER 75355, PROVIDED BY THE WATERMASTER'S OFFICE. THE WATER RIGHT IS TO BE SPLIT EVENLY BETWEEN THE TWO PARCELS, PROVIDING 4.8 ACRES OF WATER RIGHTS PER PARCEL.
- SEWAGE DISPOSAL SHALL BE PROVIDED BY A DEQ APPROVED SANITARY SEWAGE DISPOSAL SYSTEM.
- C-S-N 1/64 CORNER BEARS EAST 0.73' FROM SE CORNER OF PARCEL 3.
- SEWAGE DISPOSAL SHALL BE PROVIDED BY A DEQ APPROVED SANITARY SEWAGE DISPOSAL SYSTEM.
- PRIVATE DRAINFIELD EASEMENT INCLUDES 10' SETBACK SURROUNDING DRAINFIELD.

DECLARATION

KNOW ALL PEOPLE BY THESE PRESENTS THAT MARJORIE A. GARRISON IS THE OWNER OF THE LAND REPRESENTED ON THIS PARTITION PLAT, AND MORE PARTICULARLY DESCRIBED IN THE ACCOMPANYING SURVEYOR'S CERTIFICATE AND HAS CAUSED THE SAME TO BE PARTITIONED INTO TWO PARCELS AS SHOWN, IN ACCORDANCE WITH O.R.S. CHAPTER 92, AND DOES HEREBY GRANT THE PRIVATE IRRIGATION EASEMENT AND PRIVATE DRAINFIELD EASEMENT AS THEY APPEAR ON THIS PLAT IN ADDITION TO THE DITCH EASEMENT NOTED ON THIS PLAT.

Marjorie A. Garrison
MARJORIE A. GARRISON



ACKNOWLEDGMENT

ON July 16th, 2010 BEFORE ME DID PERSONALLY APPEAR THE WITHIN NAMED MARJORIE A. GARRISON WHO ACKNOWLEDGED TO ME THAT SHE EXECUTED THE SAME FREELY AND VOLUNTARILY.

STATE OF Oregon }
COUNTY OF Baker } S.S.

Karen Phillips
NOTARY PUBLIC
MY COMMISSION EXPIRES 11-1-2010

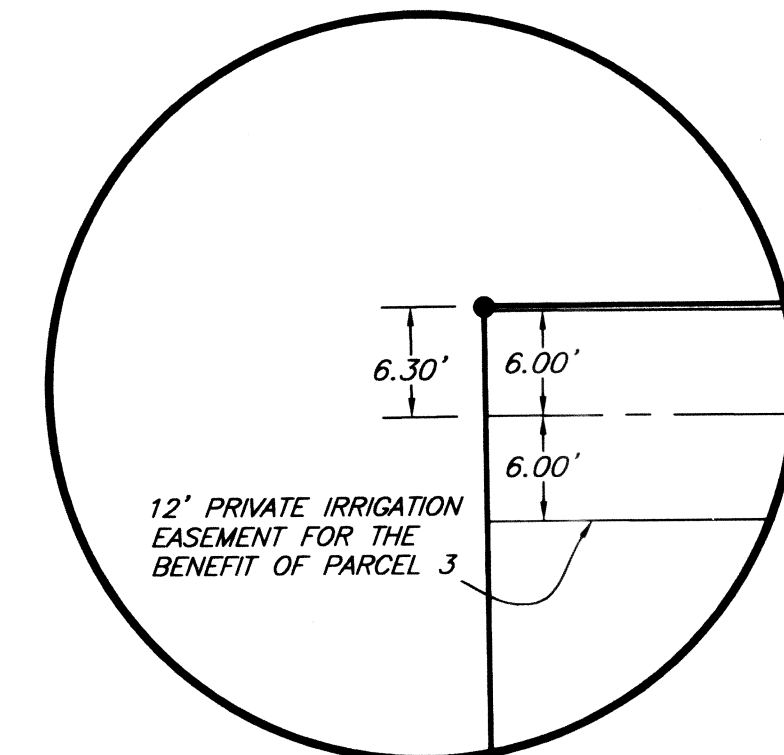
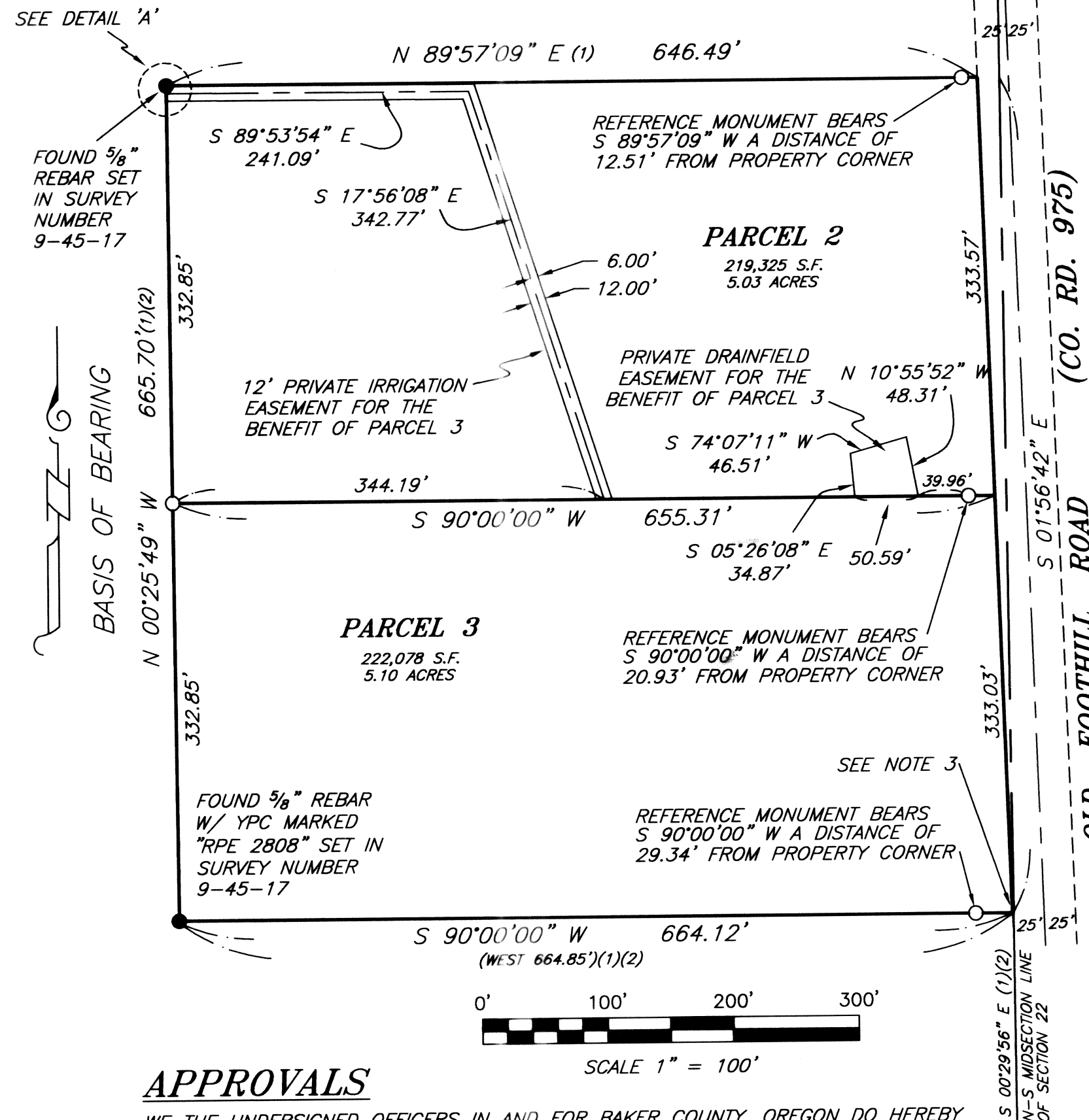

DETAIL 'A'
NOT TO SCALE

NARRATIVE

HANLEY ENGINEERING, INC. WAS EMPLOYED BY MARJORIE A. GARRISON FOR THE PURPOSE OF PARTITIONING PARCEL 2 OF MINOR PARTITION PLAT P1994-012 INTO TWO PARCELS.

BAKER COUNTY ROAD WIDTH ASSUMED TO BE 50' AND CENTERED BETWEEN EXISTING FENCE CULTURE. THIS WIDTH AND LOCATION DIFFERS FROM REFERENCED PARTITION PLAT P1994-012. PROPERTY LINE WAS ALSO ASSUMED TO FOLLOW THE DESCRIPTION OF PARCEL 2 IN P1994-012 WITH THE EXCEPTION OF THE EASTERN BOUNDARY WHICH WAS ASSUMED TO BE THE WESTERN R/W LINE OF OLD FOOTHILL ROAD (CO. RD. 975).

REFERENCES

- BAKER COUNTY SURVEY #9-45-17
- MINOR PARTITION PLAT P1994-012
- STATUTORY WARRANTY DEED NO. B99 40 120
- BAKER COUNTY STAFF REPORT MnP-09-007, DATED NOV. 19, 2009

LEGEND

- - FOUND MONUMENT AS NOTED.
- - SET 5/8\"/>

APPROVALS

WE THE UNDERSIGNED OFFICERS IN AND FOR BAKER COUNTY, OREGON DO HEREBY APPROVE THIS MINOR PARTITION PLAT.

BAKER COUNTY SURVEYOR BY: *Thomas J. Hanley* DATE 7/16/10
DEPUTY BAKER COUNTY SURVEYOR

BAKER COUNTY PLANNING BY: *Holly Starnes* DATE 7/19/10

I HEREBY CERTIFY THAT ALL TAXES FOR THE SUBJECT PROPERTY HAVE BEEN PAID AS REQUIRED.

BAKER COUNTY TAX COLLECTOR BY: *Nice Durbin* DATE 7/19/10

STATE OF Oregon }
COUNTY OF Baker } S.S. I DO HEREBY CERTIFY THAT THIS MINOR PARTITION PLAT WAS RECEIVED FOR RECORDING ON THE 19th DAY OF JULY, 2010, AT 4:00 O'CLOCK P.M. AND RECORDED IN BAKER COUNTY RECORDS AND IS HEREBY APPROVED.

BAKER COUNTY CLERK BY: *Jamara J. Green* Co. Clerk
by *Karen Phillips*, Deputy

